



Meeting the Industry's
Low Lead-free
Requirements



3 Year
Limited
Warranty

**DUCTILE IRON &
STAINLESS STEEL Butterfly Valves**
2"–24" 200/150 PSI Bi-Directional Service

DeltaT 050/051 & 650/651 Butterfly Valves

Features & Benefits

050/051

Lug/Wafer-Style Ductile Iron Body

650/651

Lug/Wafer-Style Stainless Steel Body

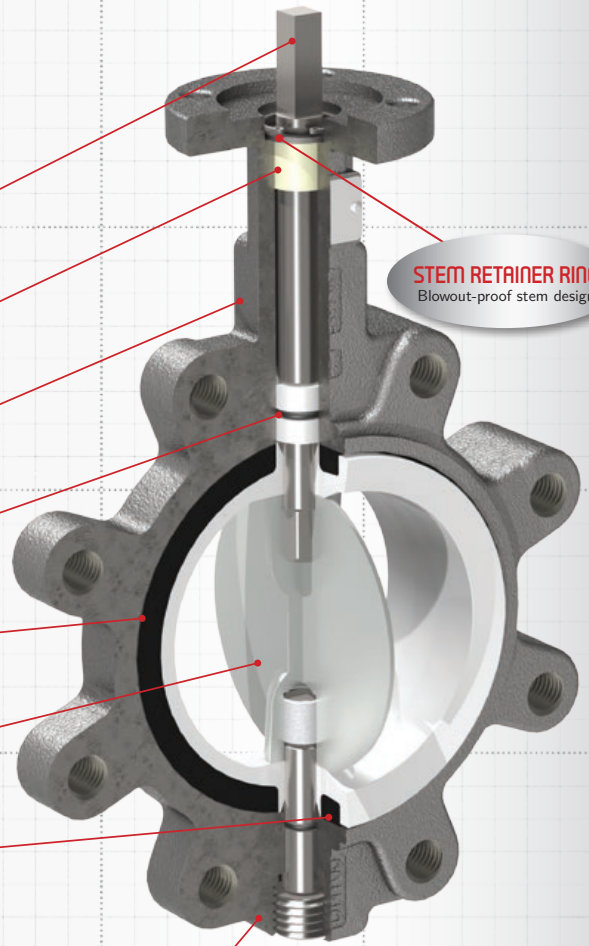
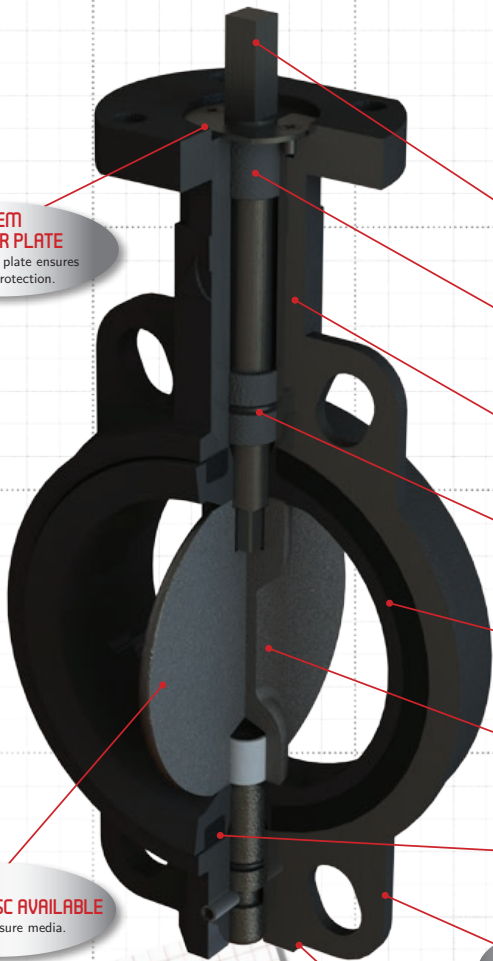

STEM RETAINER PLATE
Stem retainer plate ensures blowout protection.

DRIVE STEM
Easy direct-mount automation with ISO 5211 standard drive stem and mounting flange.

STEM RETAINER RING
Blowout-proof stem design

STEM BUSHINGS
Graphite-reinforced PTFE stem bushings provide for low torque and incredibly long cycle life!

EXTENDED NECK
Allows use with insulated pipes.

SECONDARY PROTECTION
Secondary o-ring stem seal protection.

SEAT
Cartridge-style seat allows field replacement.

NO TAPER PINS
No taper pins on disc ensures trouble-free service and better flow performance.

BACKING RING
Rigid backing ring allows for dead-end service.

UNDERCUT DISC AVAILABLE
for low pressure media.

EPOXY POWDER COATING
as standard

DUCTILE IRON BODY
Durable and economical.

STAINLESS STEEL BODY
Tough and corrosion-resistant construction.

2" VALVE BODIES AVAILABLE WITH 1/2" CLASS 150 WAFER-STYLE FLANGE

050/051 SIZES AVAILABLE WAFER 1/2" - 48"* LUG 2" - 48"*

Features & Benefits

- Sizes 2" through 24" available from stock, wafer or lug
- Lug-style dead end service capabilities through 12":
200 PSI uni-directional
100 PSI bi-directional
- Install between Standard ANSI class 125/150 flanges
- ISO 5211 square drive shaft for easy automation
- Conforms to MSS-SP-67, MSS-SP-25, API-609
- Designed for blowout-proof service
- High-Cv slim disc & 2-piece stem design 2"-12"
- Field repairable
- Vacuum service capable 2" thru 12" to 10 microns
- Dead end service for 650/651 Series coming soon
- CRN registration

650/651: SIZES AVAILABLE WAFER & LUG 2" - 24"



*For sizes larger than 24", please consult factory

DeltaT 050/051 & 650/651 Butterfly Valves

Ordering Guidelines & Trim Codes

Ordering Guideline

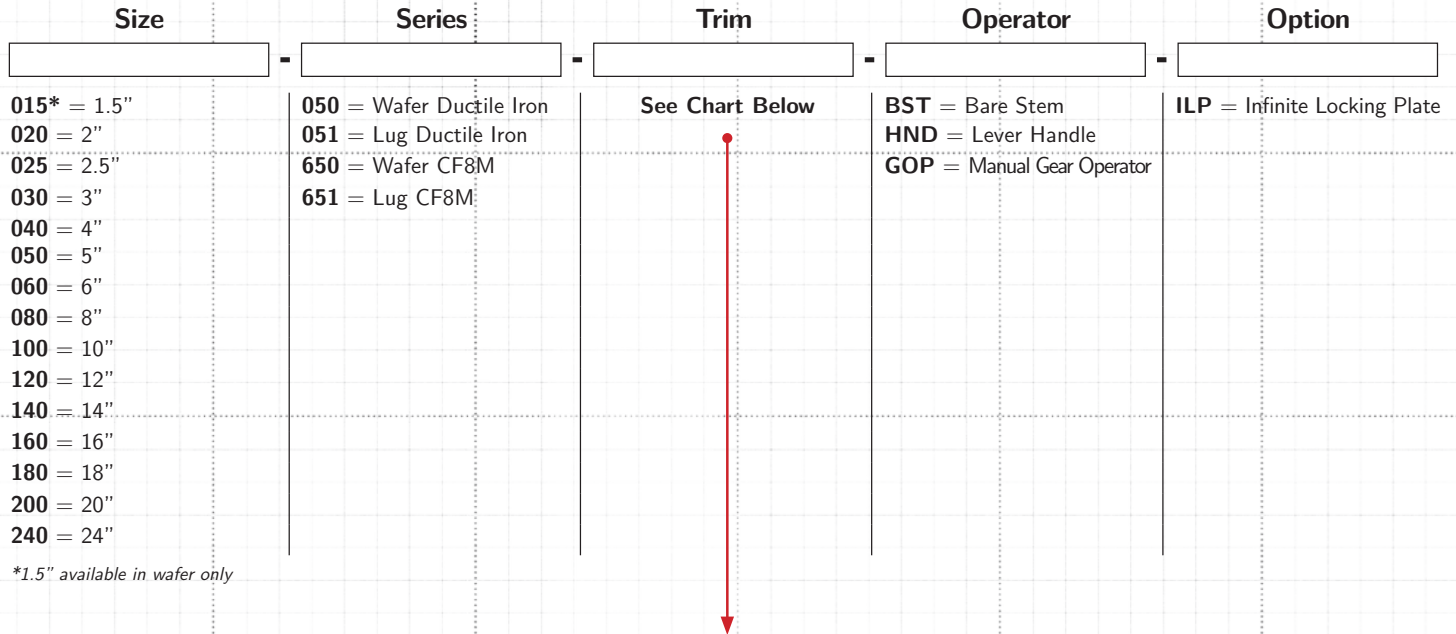

Trim Codes	Body	Disc	Stem	Seat
262	DI	DI-NI-PL	416 SS	EPDM
263	DI	DI-NI-PL	416 SS	BUNA
264	DI	DI-NI-PL	416 SS	VITON
265	DI	DI-NI-PL	416 SS	BLACK FOOD EPDM
266	DI	DI-NI-PL	416 SS	WHITE FOOD EPDM
897	DI	NY11	416 SS	EPDM
898	DI	NY11	416 SS	BUNA
899	DI	NY11	416 SS	VITON
900	DI	NY11	416 SS	BLACK FOOD EPDM
901	DI	NY11	416 SS	WHITE FOOD EPDM
780	DI	AB	416 SS	EPDM
783	DI	AB	416 SS	BUNA
784	DI	AB	416 SS	BLACK FOOD EPDM
785	DI	AB	416 SS	WHITE FOOD EPDM
788	DI	AB	416 SS	VITON
579	DI	CF8M	416 SS	EPDM
582	DI	CF8M	416 SS	BUNA
585	DI	CF8M	416 SS	BLACK FOOD EPDM
589	DI	CF8M	416 SS	WHITE FOOD EPDM
590	DI / CF8M	CF8M	416 SS / 431 SS	HIGH TEMP EPDM
962	DI	CF8M	416 SS	VITON
482	DI / CF8M	CF8M	416 SS / 431 SS	PTFE/EPDM
463	DI / CF8M	PTFE over CF8M	416 SS / 431 SS	PTFE/EPDM
464	CF8M	PTFE over CF8M	431 SS	VITON
360	CF8M	PTFE over CF8M	431 SS	BLACK FOOD EPDM
930	CF8M	PTFE over CF8M	431 SS	WHITE FOOD EPDM
479	CF8M	Polished CF8M	431 SS	EPDM
465	CF8M	Polished CF8M	431 SS	BUNA
482P	DI / CF8M	Polished CF8M	416 SS / 431 SS	PTFE/EPDM
492	CF8M	Polished CF8M	431 SS	VITON
380	CF8M	Polished CF8M	431 SS	BLACK FOOD EPDM
950	CF8M	Polished CF8M	431 SS	WHITE FOOD EPDM

DeltaT 050/051 Butterfly Valves 2"-12"

050/051 Exploded View

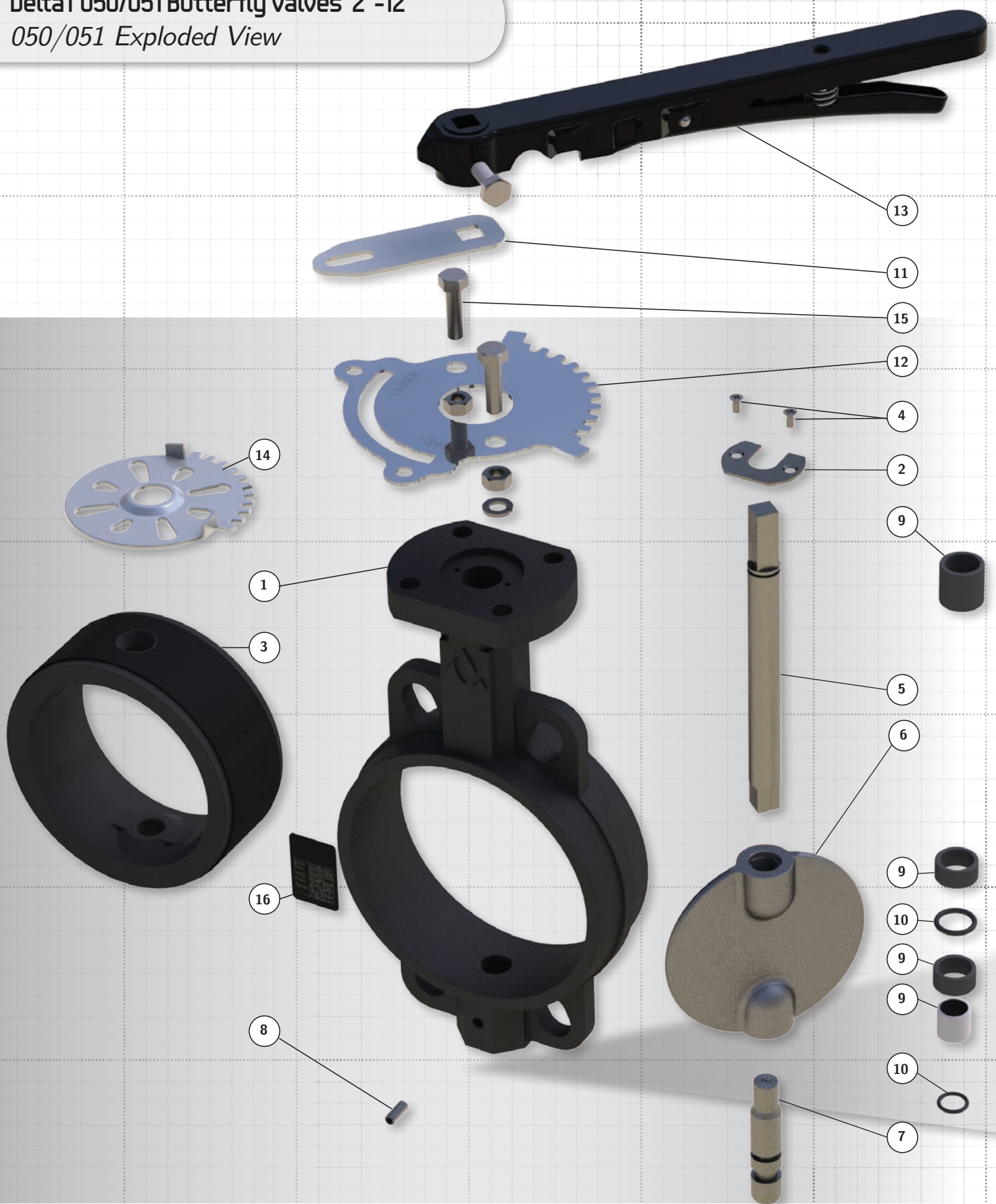

DeltaT 050/051 Butterfly Valves 2"-12" 050/051 Materials and Stem Details

050/051 Series

Item	Description	Materials
1	Body	Ductile Iron ASTM A536
2	Stem Retainer	Carbon Steel, Plated
3	Seat	See Pg 3 or 18
4	Stem Retainer Screws	Carbon Steel, Plated
5	Upper Stem	Stainless Steel ASTM A582, Alloy 416
6	Disc	See Pg 3
7	Lower Stem	Stainless Steel ASTM A582, Alloy 416
8	Lower Stem Retainer	Carbon Steel, Plated
9	Bushing	PTFE/Graphite
10	O-Ring	EPDM, BUNA-N, Fluoroelastomer
11*	Locking Arm*	Carbon Steel, Plated
12*	Infinite Lever* Plate	Carbon Steel, Plated
13	Lever Handle	Stamped Steel, Epoxy Coated (Standard)
14	Throttle Plate	Carbon Steel, Plated (Standard)
15	Bolt	Carbon Steel, Plated
16	Nameplate Tag	Aluminum

**Optional accessory. It is important to note that the infinite lever plate and locking arm is only lockable in the full open or full closed positions.*

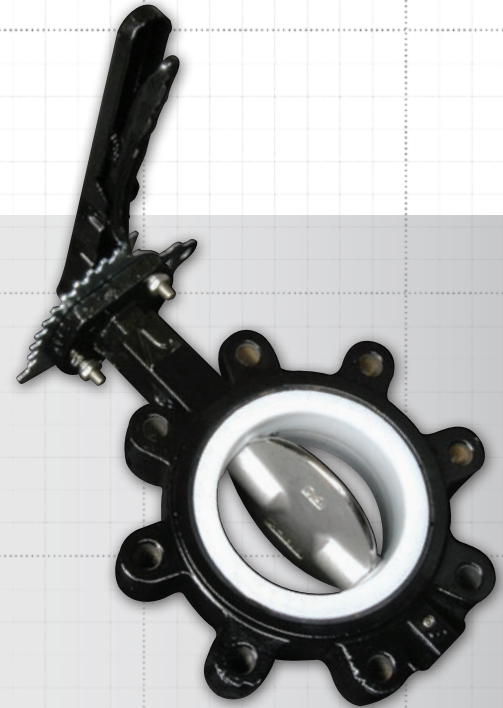

Lower Stem Detail

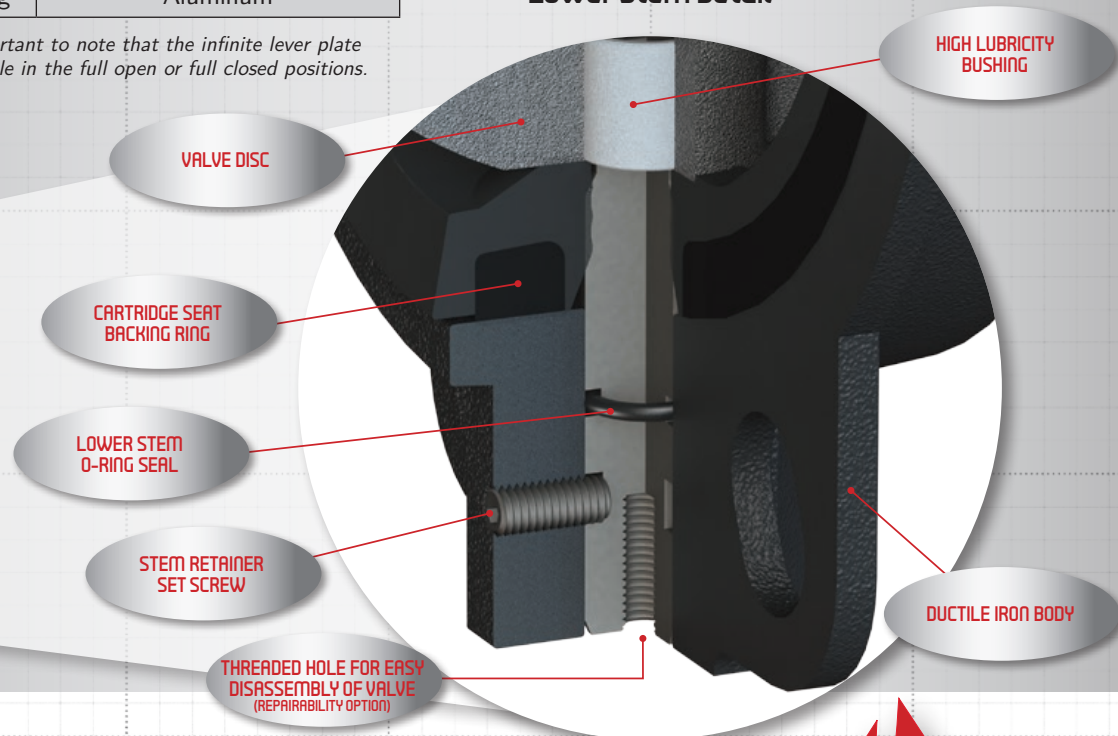

DeltaT 050/051 Butterfly Valves 14"-24"
050/051 Exploded View

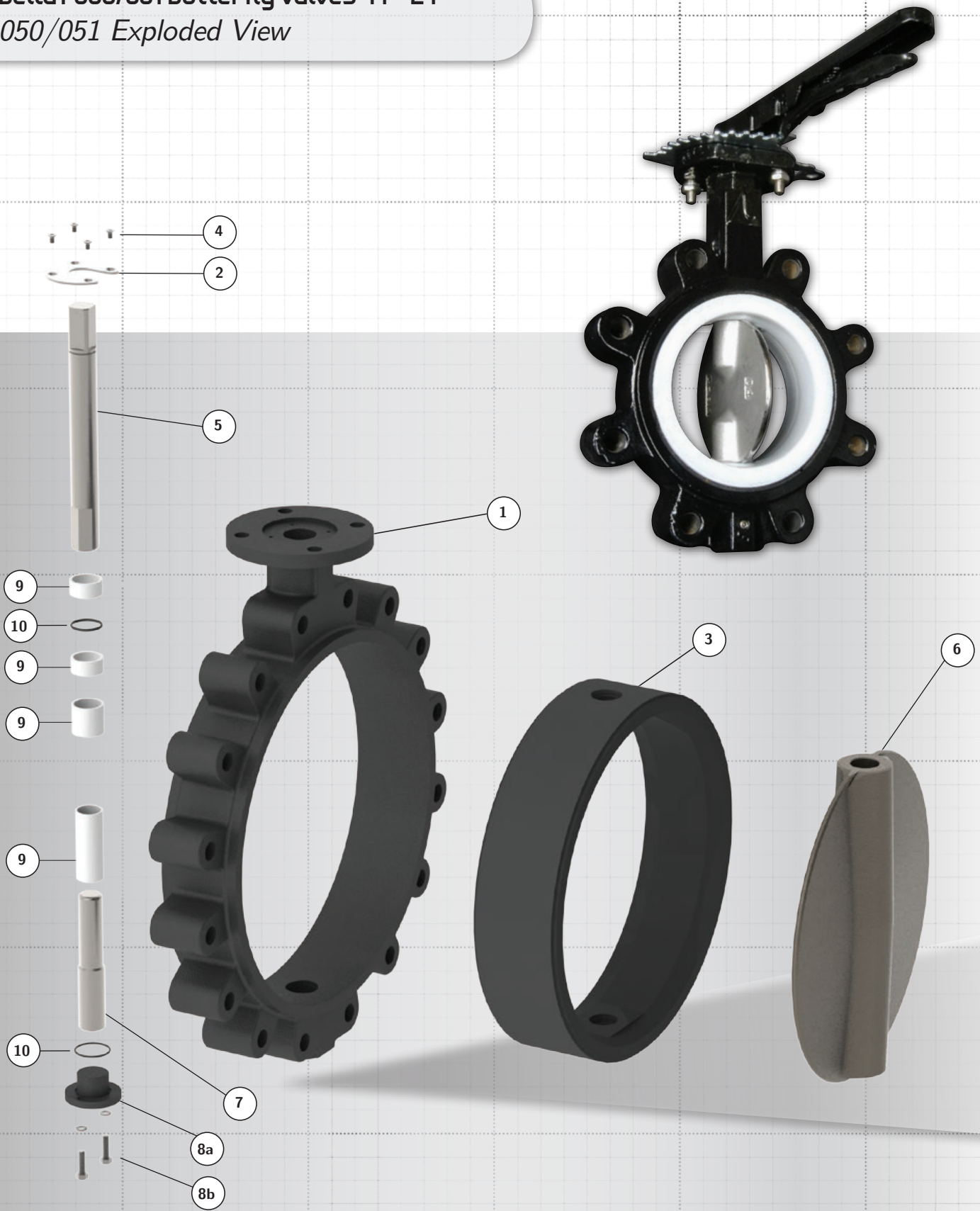

050/051 Series

Item	Description	Materials
1	Body	Ductile Iron ASTM A536
2	Stem Retainer	Carbon Steel, Plated
3	Seat	See Pg 3 or 18
4	Stem Retainer Screws	Carbon Steel, Plated
5	Upper Stem	Stainless Steel ASTM A582, Alloy 416 or 410
6	Disc	See Pg 3
7	Lower Stem	Stainless Steel ASTM A582, Alloy 416 or 410
8a	Lower Stem Retainer	Ductile Iron ASTM A536
8b	Lower Stem Retainer Bolts and Washers	Carbon Steel, Plated
9	Bushing	PTFE/Graphite
10	O-Ring	EPDM, BUNA-N, Fluoroelastomer

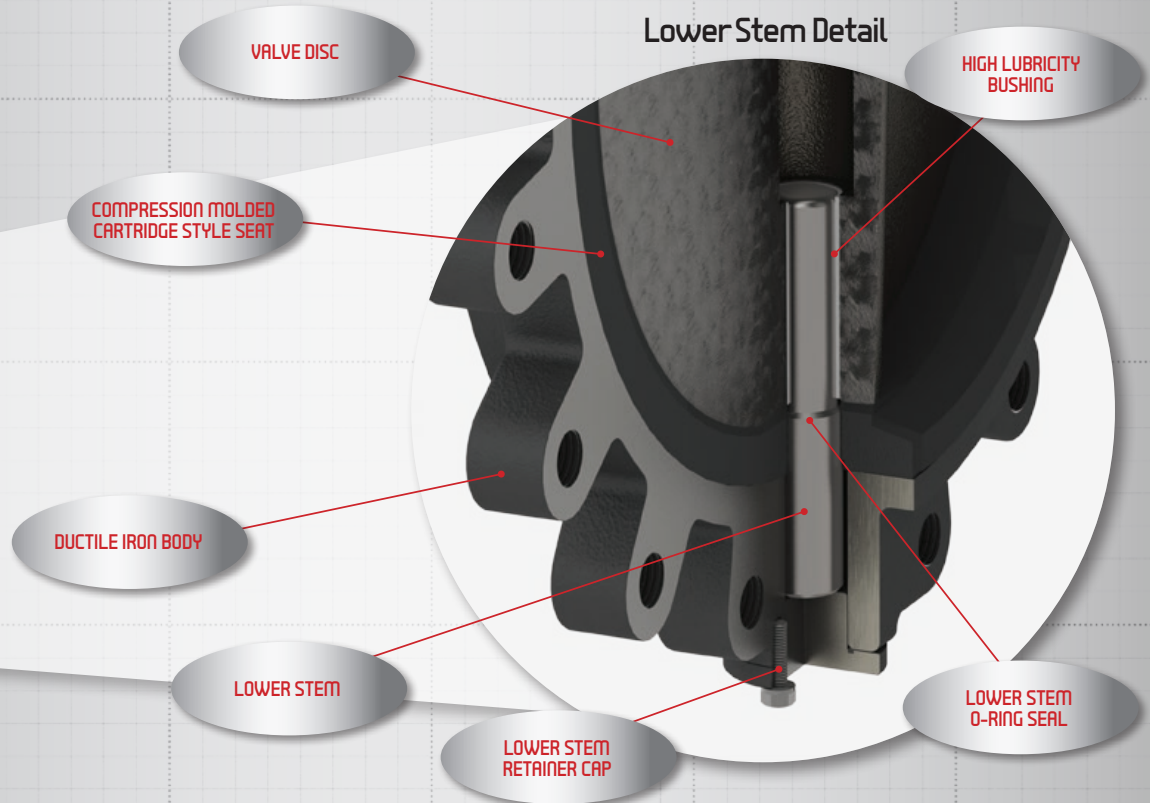

DeltaT 650/651 Butterfly Valves 2"-12"

650/651 Exploded View

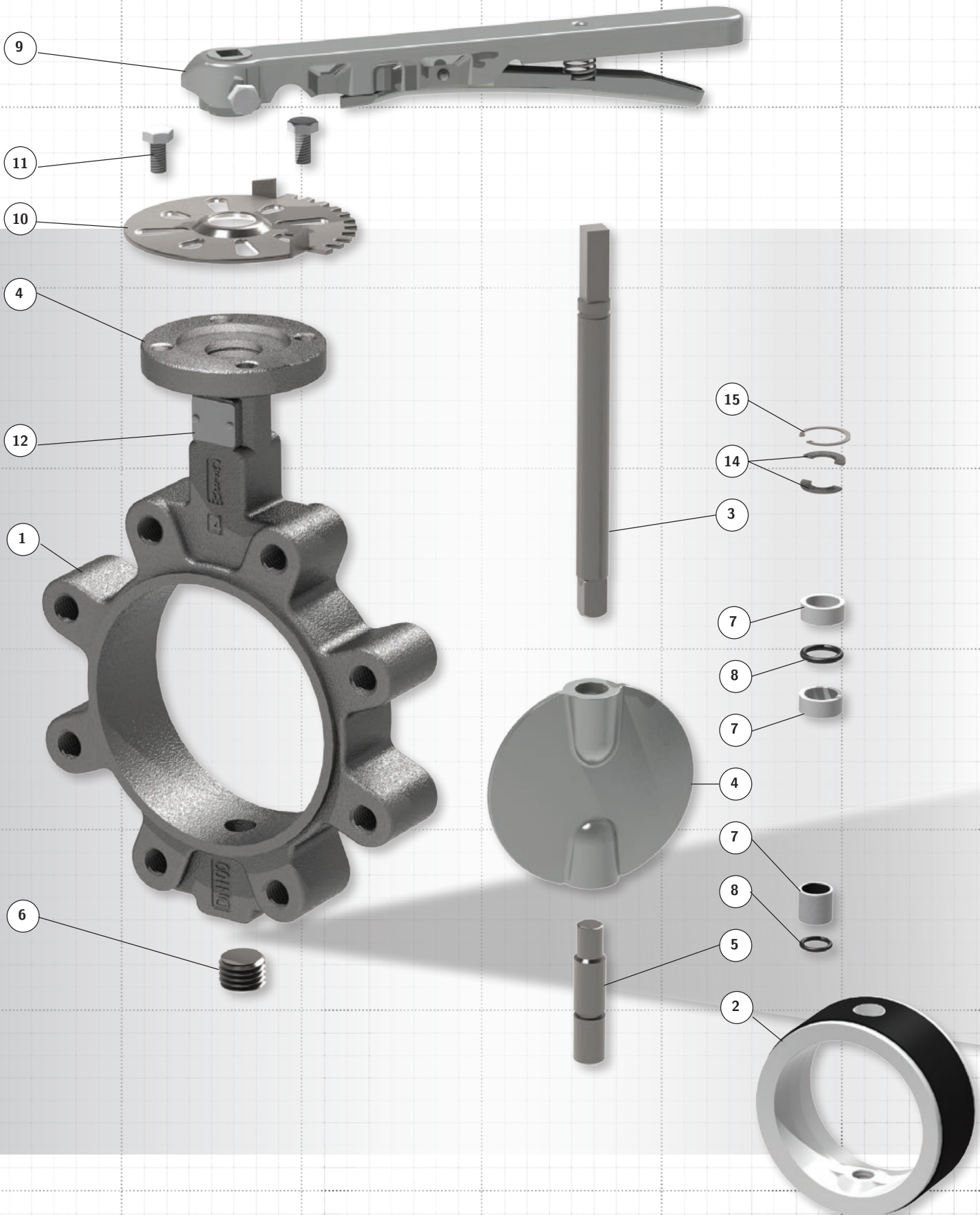

DeltaT 650/651 Butterfly Valves 2"-12" 650/651 Materials and Stem Detail

650/651 Series

Item	Description	Materials
1	Body	ASTM A351 grade CF8M
2	Seat	See Pg 3 or 18
3	Upper Stem	ASTM A276 431 SS*
4	Disc	See Pg 3
5	Lower Stem	ASTM A276 431 SS*
6	Lower Stem Retainer	304 SS
7	Stem Bushing	PTFE lined fiberglass
8	O-ring	Fluoroelastomer
9	Lever Handle	304 SS
10	Throttle Plate	304 SS
11	Bolting	304 SS
12	Nameplate Tag	Stainless Steel
14	Split Washer	1Cr13
15	Snap Ring	304 SS

*316 stainless steel option available for stem

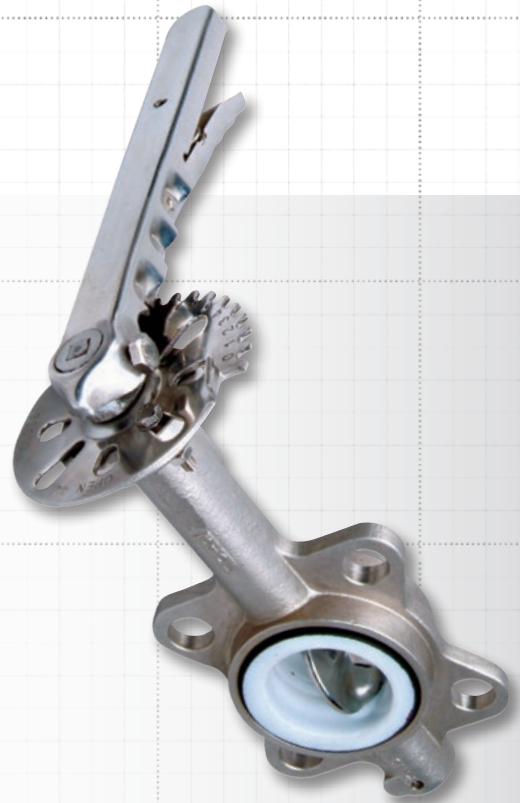

Lower Stem Detail

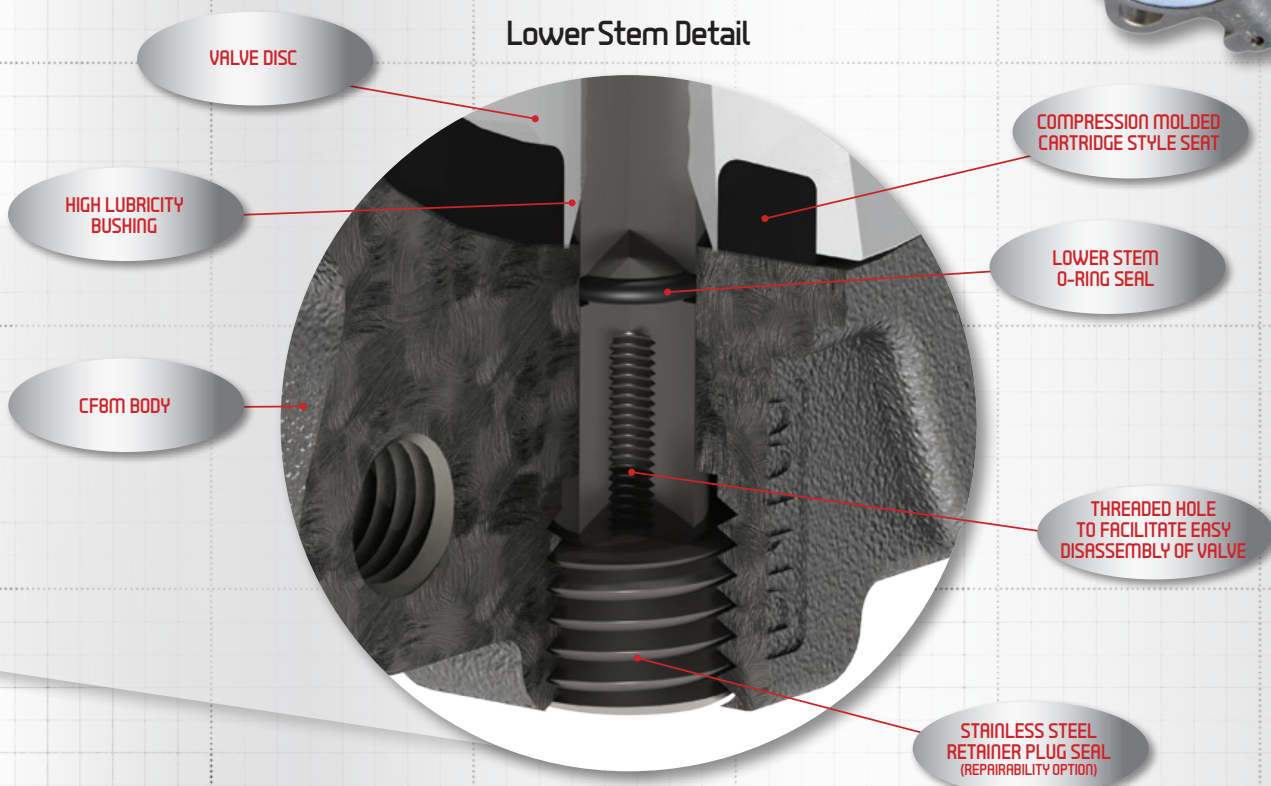

DeltaT 650/651 Butterfly Valves 14"-24"
650/651 Exploded View

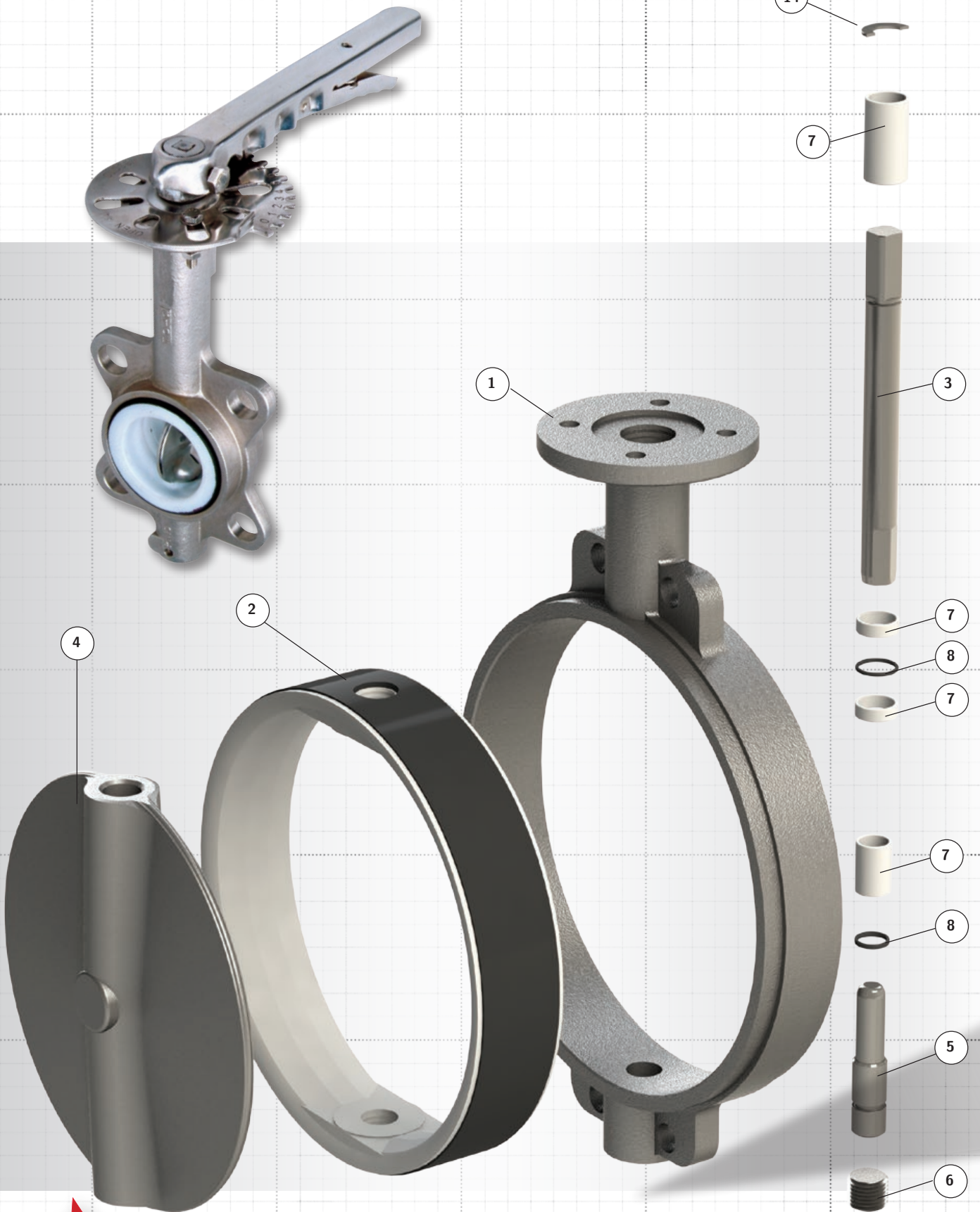

DeltaT 650/651 Butterfly Valves 14"-24" 650/651 Materials and Stem Detail

650/651 Series

Item	Description	Materials
1	Body	ASTM A351 grade CF8M
2	Seat	See Pg 3 or 18
3	Upper Stem	ASTM A276 431 SS*
4	Disc	See Pg 3
5	Lower Stem	ASTM A276 431 SS*
6	Lower Stem Retainer	304 SS
7	Stem Bushing	PTFE lined fiberglass
8	O-ring	Fluoroelastomer
14	Split Washer	1Cr13
15	Snap Ring	304 SS

*316 stainless steel option available upon request, special order item only

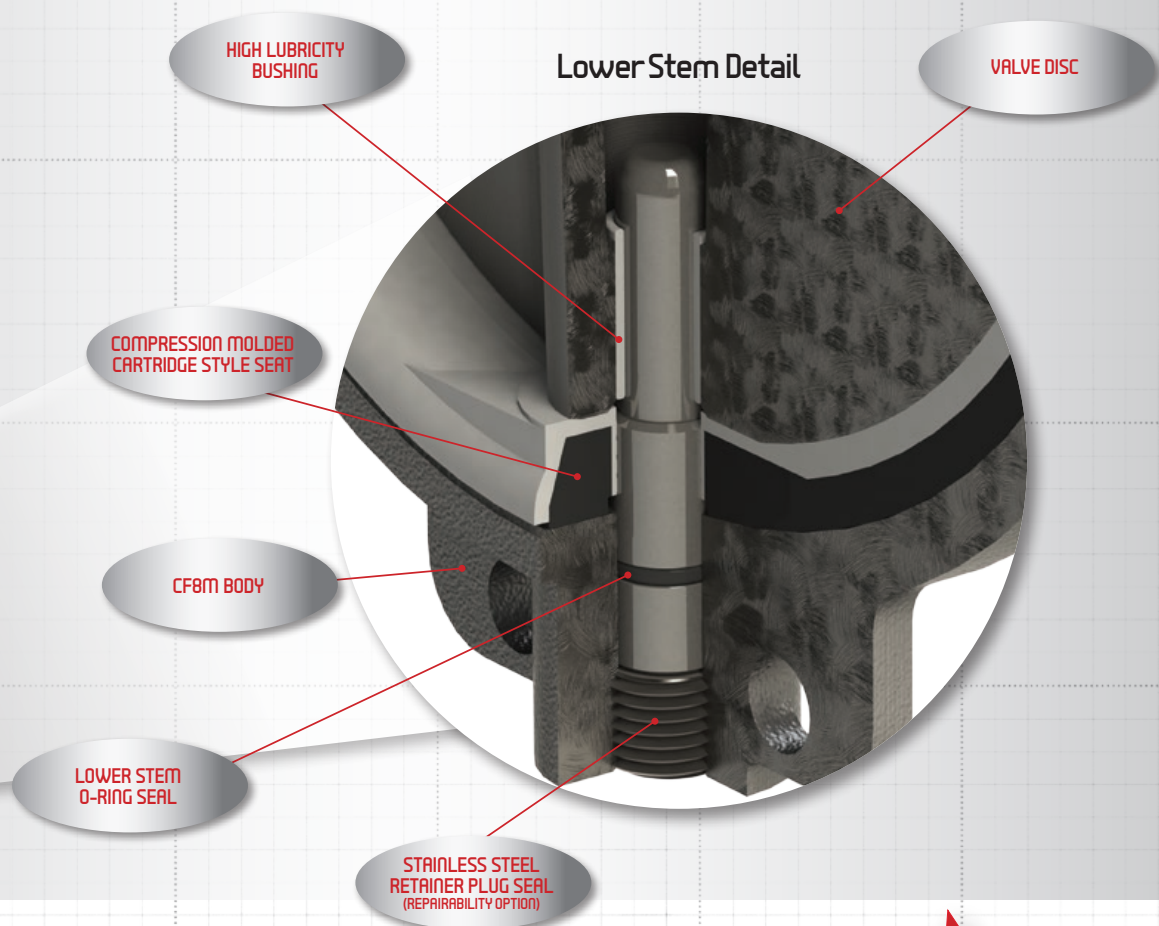

DeltaT 050/051 & 650/651 Butterfly Valves

Torque & Service Factor Ratings

050/051 SERIES Valve Seating Torques (in-lbs)

Size (in)	Standard Disc & Seat (not PTFE) @ Pressure Differential (ΔP in PSI)				
	Fullcut				Undercut
	50 ΔP	100 ΔP	150 ΔP	200 ΔP	
2	105	111	117	124	—
2½	133	143	159	184	—
3	191	203	218	247	—
4	283	316	343	373	200
5	428	479	540	631	330
6	636	720	799	909	440
8	1239	1273	1411	1505	820
10	2567	2710	2832	3105	1150
12	3153	3307	3671	4305	2400
14	3858	4138	4337	—	Consult Manufacturer
16	5413	6027	7466	—	
18	6833	8121	10089	—	
20	9820	10527	13367	—	
24	15909	17005	21041	—	

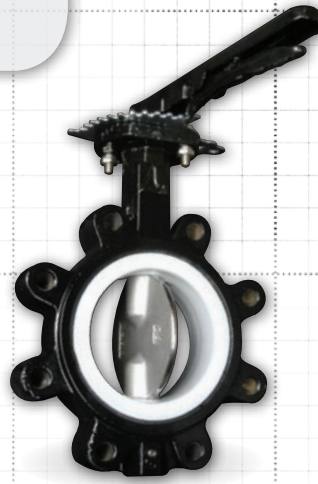

For PE Seats (PTFE over EPDM) used in 050/051 Series, follow torques as shown in 650/651 Series.

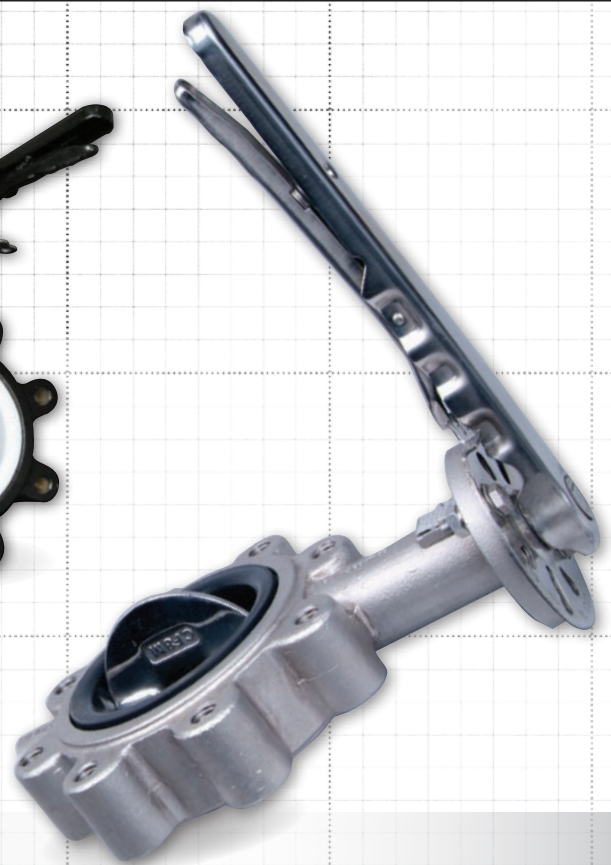

650/651 SERIES Valve Seating Torques (in-lbs)

Size (in)	STANDARD SEAT (code B,E,V, etc)				PTFE SEAT (code PE)		
	Pressure Differential (ΔP in PSI)				Pressure Differential (ΔP in PSI)		
	50 ΔP	100 ΔP	150 ΔP	200 ΔP	50 ΔP	100 ΔP	150 ΔP
2	105	111	117	124	144	148	150
2½	133	143	159	184	161	165	168
3	191	203	218	247	299	304	310
4	283	316	343	373	392	409	425
5	428	479	540	631	771	793	814
6	636	720	799	909	1074	1113	1151
8	1239	1273	1411	1505	2106	2177	2257
10	2567	2710	2832	3105	3151	3301	3452
12	3153	3307	3671	4305	4186	4443	4691
14	3858	4138	4337	—	Consult Manufacturer		
16	5413	6027	7466	—			
18	6833	8121	10090	—			
20	9820	10527	13367	—			
24	15909	17005	21041	—			

The torque values listed above do not include a safety factor. It is recommended that a safety factor of 20% be added to these numbers for standard self-lubricating service. For water, dry air, solvents, abrasives, powder, and dust service, see service factor guide chart below.



Cartridge-style seats provide superior performance to booted or molded seats.

2" Thru 12" Full Vacuum to 10 Microns

Service Factor Rating

Service Condition	Service Type	Media Type	Safety Factor	Multiplier
1	Ideal	Lubricating Oil	20%	1.20
2	Normal	Water	30%	1.30
3	Severe	Dry Air, Solvents	50%	1.50
4	Extreme	Abrasives	100%	2.00

This service factor chart is a suggested guide only. Actual service conditions will vary due to dynamic flow conditions and may require adjustments to the applied safety factor.

DeltaT 050/051 & 650/651 Butterfly Valves CV Values & Testing Specs

050/051 SERIES & 650/651 SERIES Cv Values Valve Sizing Coefficients (US-GPM/ ΔP)

Size (in)	Disc Position								
	90°	80°	70°	60°	50°	40°	30°	20°	10°
1½	99	76	59	41	32	16	7	1.8	0.1
2	132	120	86	58	42	22	11	2	0.1
2½	256	202	142	98	65	37	20	4	0.2
3	505	392	198	125	86	38	21	8	0.3
4	936	702	401	232	140	77	35	14	0.4
5	1109	922	625	392	232	132	62	29	0.9
6	2531	2009	1105	611	372	203	96	42	2.1
8	4812	3555	1901	1211	726	401	191	65	3.2
10	7498	6183	3740	2065	1232	695	321	151	3.9
12	9928	8805	5905	3178	1909	1065	495	234	5
14	12915	10854	7220	4560	2771	1554	712	338	5.8
16	16626	14961	9909	6289	3780	2133	980	460	8
18	23705	19743	13178	8325	5029	2822	1301	613	10
20	27915	25396	16928	10698	6468	3623	1678	790	12
24	43212	39206	26128	16550	9807	5567	2521	860	21

The valve sizing coefficient is referred to as "Cv" and is the rate of water flow in gallons per minute (GPM) through a given opening at a pressure drop (ΔP) of 1 PSI at standard room temperature. The recommended angle of opening for valve sizing is between 50° and 70° open.

Standard 10-Position
Throttle Plate Shown

050/051 SERIES & 650/651 SERIES Testing Specifications

	050/051 & 650/651 SERIES		
Nominal Size	2"-12" (EPDM)	14"-24" (EPDM)	2"-12" (PTFE)
Nominal Pressure	200 PSI*	150 PSI	150 PSI
Body Test Pressure	300 PSI	225 PSI	225 PSI
Sealing Test Pressure	220 PSI	165 PSI	165 PSI

*PTFE seats are rated to 150 PSI

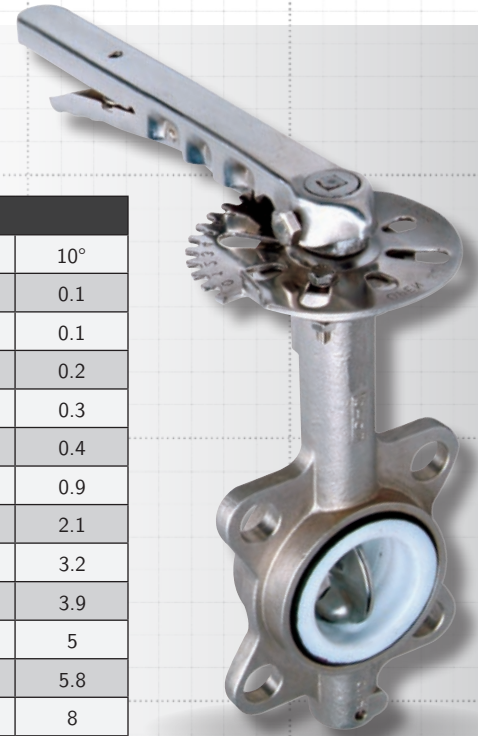

DeltaT 050/051 Butterfly Valves

050/051 Dimensions

050/051 SERIES—Ductile Iron

Size		L		Q		ØD1		n - Th	n - Øh		H1		H2		H3		S		ØF		ISO	Wafer Weight		Lug Weight	
in	mm	in	mm	in	mm	in	mm	SAE Thread	in	mm	in	mm	in	mm	in	mm	in	mm	in	mm		lbs	kg	lbs	kg
1½	DN40	1.3	33	0.8	21	3.88	98.5	½"- 13 UNC	4 x 0.7	4 x 18	2.5	64	4.9	124	1.18	30	0.354	9	1.969	50	F05	—	—	—	—
2	DN50	1.7	43	1.1	29	4.75	120.7	4 x ⅝-11 UNC	4 x 0.9	4 x 22	2.6	66	5.1	130	1.18	30	0.354	9	1.969	50	F05	4.2	1.9	5.2	2.4
2½	DN65	1.8	46	1.8	45	5.50	139.7	4 x ⅝-11 UNC	4 x 0.7	4 x 18	3.2	81	5.6	142	1.18	30	0.354	9	1.969	50	F05	5.5	2.5	6.5	3.0
3	DN75	1.8	46	2.5	62	6.00	152.4	4 x ⅝-11 UNC	4 x 0.7	4 x 18	3.5	89	5.8	147	1.18	30	0.354	9	1.969	50	F05	6.1	2.8	7.3	3.3
4	DN100	2.0	52	3.5	89	7.50	190.5	8 x ⅝-11 UNC	4 x 0.7	4 x 18	4.3	109	6.7	170	1.18	30	0.433	11	2.756	70	F07	9.0	4.1	12.5	5.7
5	DN125	2.2	56	4.6	116	8.50	215.9	8 x ¾-10 UNC	4 x 0.9	4 x 22	4.8	122	7.4	188	1.18	30	0.551	14	2.756	70	F07	12.6	5.7	16.9	7.7
6	DN150	2.2	56	5.7	145	9.50	241.3	8 x ¾-10 UNC	4 x 0.9	4 x 22	5.4	137	8.0	203	1.18	30	0.551	14	2.756	70	F07	15.1	6.9	20.4	9.3
8	DN200	2.4	60	7.8	197	11.75	298.5	8 x ¾-10 UNC	4 x 1.0	4 x 26	6.7	170	9.4	239	1.57	40	0.669	17	4.016	102	F10	27.0	12.3	33.3	15.1
10	DN250	2.7	68	9.8	248	14.25	362.0	12 x 7/8-9 UNC	4 x 1.0	4 x 26	7.9	201	10.7	272	1.57	40	0.866	22	4.016	102	F10	40.8	18.5	54.5	24.7
12	DN300	3.1	78	11.7	298	17.00	431.8	12 x 7/8-9 UNC	4 x 1.0	4 x 26	9.3	236	12.0	305	1.57	40	0.866	22	4.016	102	F10	60.7	27.6	76.2	34.6
14	DN350	3.1	78	—	—	18.75	476.3	12 x 1-8 UNC	—	—	10.3	262	13.0	330	1.57	40	0.866	22	4.016	102	F10	86.9	39.4	131.5	59.7
16	DN400	4.0	102	—	—	21.25	539.8	16 x 1-8 UNC	—	—	11.8	300	14.2	361	2.00	51	1.063	27	5.512	140	F14	121.4	55.1	194.8	88.4
18	DN450	4.5	114	—	—	22.75	577.9	16 x 1 1/8-7 UNC	—	—	12.8	325	15.6	396	2.00	51	1.063	27	5.512	140	F14	154.2	69.9	235.5	106.8
20	DN500	5.0	127	—	—	25.00	635.0	20 x 1 1/8-7 UNC	—	—	14.2	361	17.3	439	2.52	64	1.063	27	6.496	165	F16	208.5	94.6	340.5	154.4
24	DN600	6.1	154	—	—	29.50	749.3	20 x 1 1/4-7 UNC	—	—	16.5	419	19.7	500	2.76	70	1.417	36	6.496	165	F16	387.9	176.0	503.0	228.2

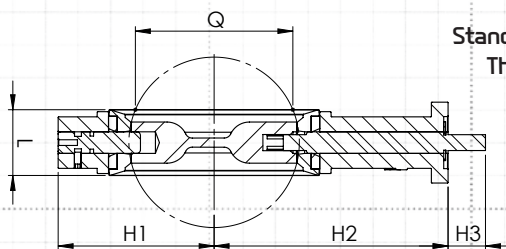
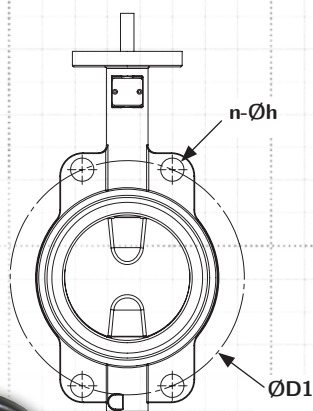

Standard 10-Position Throttle Plate

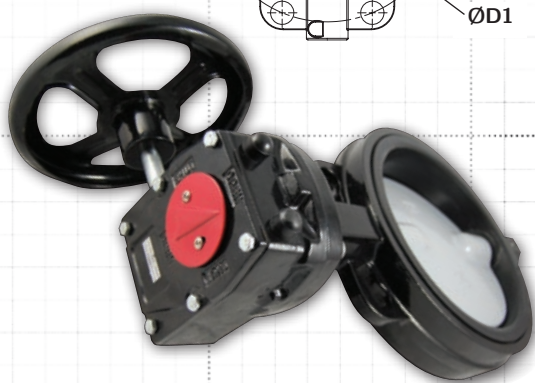
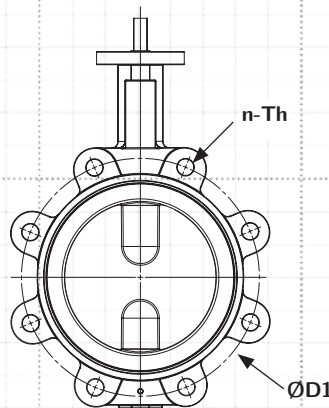
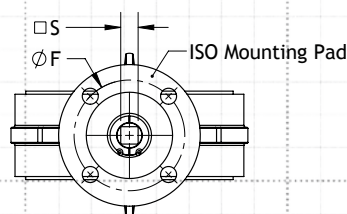

Mounting Flange Dimensions

Size	Bolt Circle Diameter (in)	Hole Size (mm)
F05	1.97	4x7
F07	2.76	4x10
F10	4.02	4x12
F14	5.51	4x18
F16	6.50	4x22

BFV STANDARDS

- VALVES DESIGNED TO
 - API-609
 - MSS-SP-25
 - MSS-SP-67
- INSTALL BETWEEN STANDARD ANSI CLASS 125/150 FLANGES
- TOP WORKS DESIGNED TO ISO 5211

DeltaT 050/051 Butterfly Valves Gear and Handle Options

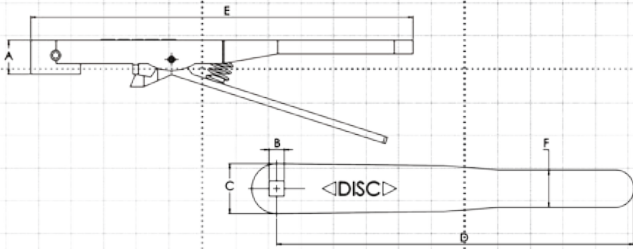

050/051 SERIES Malleable Iron Handles

Handle Part #	Valve Sizes		A		B		C		D		E		F		Weight	
	in	mm	in	mm	in	mm	in	mm	in	mm	in	mm	in	mm	lbs	kg
HND-M01	1.5-3"	DN50-75	1.0	26	0.35	9.0	1.3	33	8.9	225	9.4	240	1.1	28	1.1	2.4
HND-M02	4"	DN100	1.0	26	0.43	11.0	1.4	35	10.2	260	11.0	280	1.1	28	1.2	2.6
HND-M03	5-6"	DN125-150	1.0	26	0.55	14.0	1.4	35	10.2	260	11.0	280	1.1	28	1.3	2.9
HND-M04	8"*	DN200*	1.2	30	0.67	17.0	1.9	49	14.0	355	15.2	385	1.3	32	2.6	5.7
HND-M05	10-12"*	DN250-300*	1.2	30	0.87	22.0	1.9	49	14.0	355	15.2	385	1.3	32	2.6	5.7

*Recommended operation with a gear operator or an actuator for sizes 8"-12"

Locking arm

Infinite Lever Plate



Over-Travel on Infinite 2-Position Lock Option Allows Disc to Wipe Seat

The **standard** 10-position throttle plate has grooves that allow the handle to snap in place for repeatability and to prevent unintentional movement of the disc.

For even more control, **Infinite Lever Plates (ILP)** and arms are available, which allow the valve to be fixed in place with a bolt at any position. It is important to note that the ILP plates and locking arms can be padlocked in the full open and full closed positions only, to prevent tampering or accidental operation.

Gear Operator Padlocked Closed

ILP Shown Bolted in an Intermediate Position

ILP Shown Padlocked in the Fully Closed Position

Infinite Lever Details

Valve Sizes		ILP Plate	ILP Arm
in	mm		
2-3"	DN50-75	01	01
4"	DN100	02	03
5-6"	DN125-150	02	04
8"*	DN200*	03	05
10-12"*	DN250-300*	03	06

Gear Operator Dimensions—Cast Iron

Valve Sizes		Gear Operator	A		B		ØH		Weight		Output Torque	
in	mm		in	mm	in	mm	in	mm	lbs	kg	in-lbs	Nm
1.5-4	DN50-100	GO-01-ISO	1.7	43	3.2	81	6	152	2.8	1.3	1330	150
5-6	DN125-150	GO-02-ISO	2.5	64	3.6	91	6	152	5.6	2.5	2200	250
8-10	DN200-250	GO-03-ISO	2.4	61	4.7	119	10	254	11.5	5.2	4425	500
12-14	DN300-350	GO-04A-ISO	2.6	66	6.5	165	12	305	22.2	10.1	8850	1000
16-18	DN400-450	GO-05B-ISO	3.5	89	7.9	201	16	406	40.8	18.5	15900	1800
20	DN500	GO-06B-ISO	5.0	127	10.1	257	16	406	78.1	35.4	30090	3400
24	DN600	GO-07-ISO	6.1	155	12.4	315	16	406	101	45.8	39825	4500

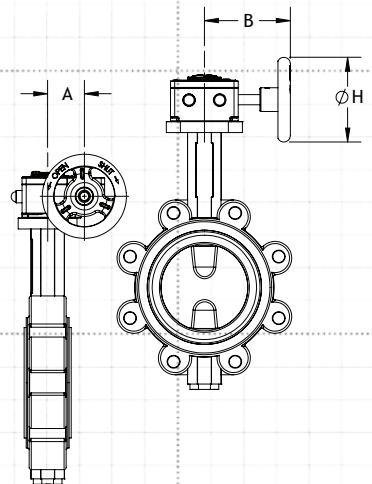

DeltaT 650/651 Butterfly Valves

650/651 Dimensions

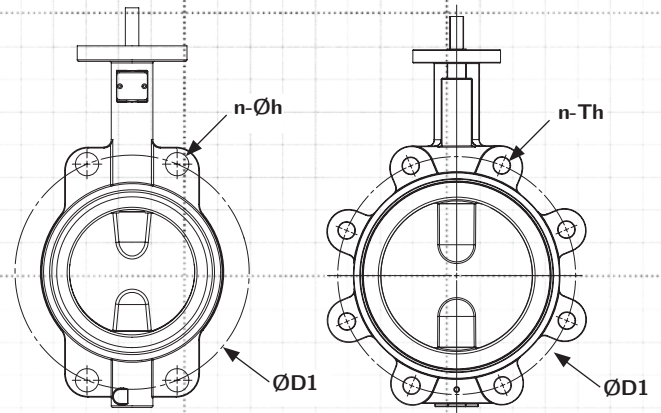
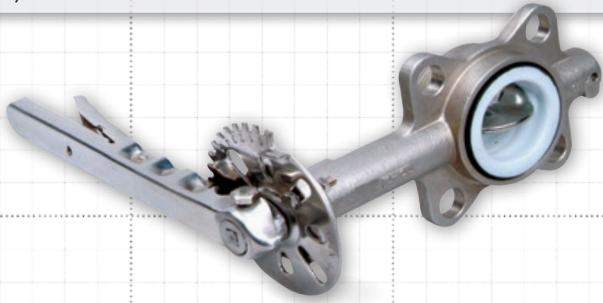

650/651 SERIES—Stainless Steel

Size		L		Q		ØD1		n - Th		n - Øh		H1		H2		H3		S		ØF		ISO	Wafer Weight		Lug Weight	
in	mm	in	mm	in	mm	in	mm	SAE Thread	in	mm	in	mm	in	mm	in	mm	in	mm	in	mm		lbs	kg	lbs	kg	
2	DN50	1.7	43	1.1	29	4.75	120.7	4 x 5/8-11 UNC	4 x 0.9	4 x 22	2.6	66	5.1	130	1.18	30	0.354	9	1.969	50	F05	6.0	2.7	10.4	4.7	
2½	DN65	1.8	46	1.8	45	5.50	139.7	4 x 5/8-11 UNC	4 x 0.7	4 x 18	3.2	81	5.6	142	1.18	30	0.354	9	1.969	50	F05	7.5	3.4	11.2	5.1	
3	DN75	1.8	46	2.5	62	6.00	152.4	4 x 5/8-11 UNC	4 x 0.7	4 x 18	3.5	89	5.8	147	1.18	30	0.433	11	1.969	50	F05	8.4	3.8	19.0	8.6	
4	DN100	2.0	52	3.5	89	7.50	190.5	8 x 5/8-11 UNC	4 x 0.7	4 x 18	4.3	109	6.7	170	1.18	30	0.433	11	2.756	70	F07	11.5	5.2	21.6	9.8	
5	DN125	2.2	56	4.6	116	8.50	215.9	8 x 3/4-10 UNC	4 x 0.9	4 x 22	4.8	122	7.4	188	1.18	30	0.551	14	2.756	70	F07	16.1	7.3	28.4	12.9	
6	DN150	2.2	56	5.7	145	9.50	241.3	8 x 3/4-10 UNC	4 x 0.9	4 x 22	5.4	137	8.0	203	1.18	30	0.551	14	2.756	70	F07	18.3	8.3	31.3	14.2	
8	DN200	2.4	60	7.8	197	11.75	298.5	8 x 3/4-10 UNC	4 x 1.0	4 x 26	6.7	170	9.4	239	1.57	40	0.669	17	4.016	102	F10	30.4	13.8	45.6	20.7	
10	DN250	2.7	68	9.8	248	14.25	362.0	12 x 7/8-9 UNC	4 x 1.0	4 x 26	7.9	201	10.7	272	1.57	40	0.866	22	4.016	102	F10	44.1	20.0	69.4	31.5	
12	DN300	3.1	78	11.7	298	17.00	431.8	12 x 7/8-9 UNC	4 x 1.0	4 x 26	9.3	236	12.0	305	1.57	40	0.866	22	4.016	102	F10	75.4	34.2	115.3	52.3	
14	DN350	3.1	78	—	—	18.75	476.3	12 x 1 - 8 UNC	—	—	10.3	262	13.0	330	1.57	40	0.866	22	4.016	102	F10	99.0	44.9	170.4	77.3	
16	DN400	4.0	102	—	—	21.25	539.8	16 x 1 - 8 UNC	—	—	11.8	300	14.2	361	2.00	51	1.063	27	5.512	140	F14	121.3	55.0	213.2	96.7	
18	DN450	4.5	114	—	—	22.75	577.9	16 x 1 1/8 - 7 UNC	—	—	12.8	325	15.6	396	2.00	51	1.063	27	5.512	140	F14	202.8	92.0	262.8	119.2	
20	DN500	5.0	127	—	—	25.00	635.0	20 x 1 1/8 - 7 UNC	—	—	14.2	361	17.3	439	2.52	64	1.063	27	6.496	165	F16	—	—	—	—	
24	DN600	6.1	154	—	—	29.50	749.3	20 x 1 1/4 - 7 UNC	—	—	16.5	419	19.7	500	2.76	70	1.417	36	6.496	165	F16	—	—	—	—	

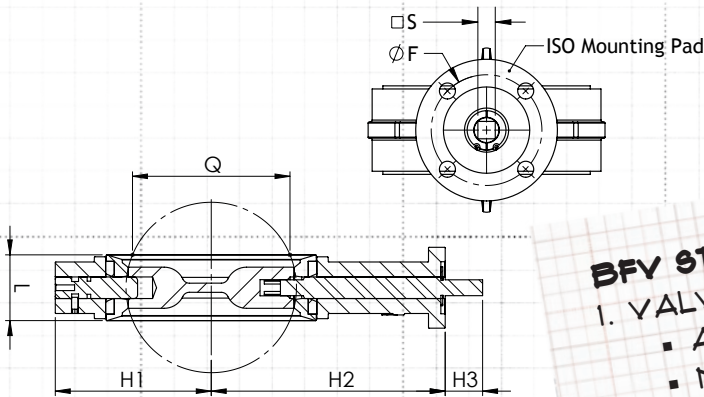

Mounting Flange Dimensions

Size	Bolt Circle Diameter (in)	Hole Size ØHD(mm)
F05	1.97	4x7
F07	2.76	4x10
F10	4.02	4x12
F14	5.51	4x18
F16	6.50	4x22

- BFV STANDARDS**
- VALVES CONFORM TO
 - API-609
 - MSS-SP-25
 - MSS-SP-67
 - INSTALL BETWEEN STANDARD ANSI CLASS 125/150 FLANGES
 - TOP WORKS DESIGNED TO ISO 5211

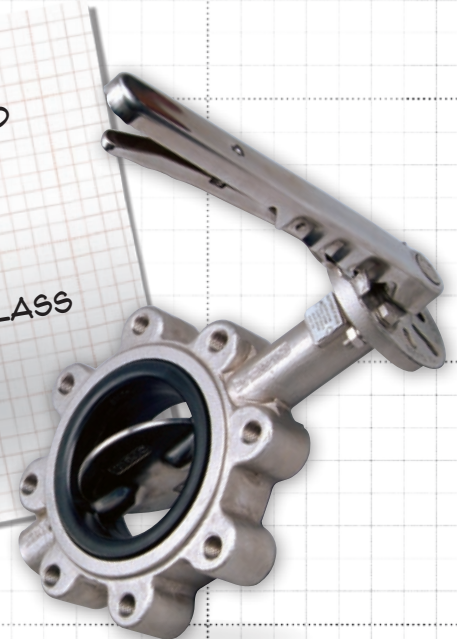

DeltaT 650/651 Butterfly Valves Gear and Handle Options

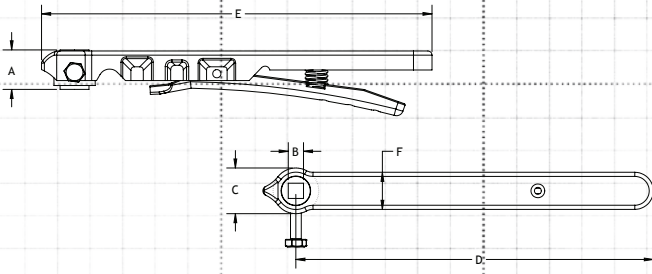

650/651 SERIES Stainless Steel Handles

Handle Part #	Valve Sizes		A		B		C		D		E		F		Weight	
	in	mm	in	mm	in	mm	in	mm	in	mm	in	mm	in	mm	lbs	kg
HND-S01	2-2.5"	DN50-75	1.1	28	0.35	9.0	1.3	34	10.2	260	11.2	285	1.1	27	1.0	2.2
HND-S02	3-4"	DN100	1.1	28	0.43	11.0	1.3	34	10.2	260	11.2	285	1.1	27	1.0	2.2
HND-S03	5-6"	DN125-150	1.1	28	0.55	14.0	1.3	34	10.2	260	11.2	285	1.1	27	1.0	2.2
HND-S04	8"*	DN200*	1.2	30	0.67	17.0	1.9	49	14.7	373	15.7	400	1.3	33	2.5	5.5
HND-S05	10-12"*	DN250-300*	1.2	30	0.87	22.0	1.9	49	14.7	373	15.7	400	1.3	33	2.5	5.5

*Recommended operation with a gear operator or an actuator for sizes 8"-12"

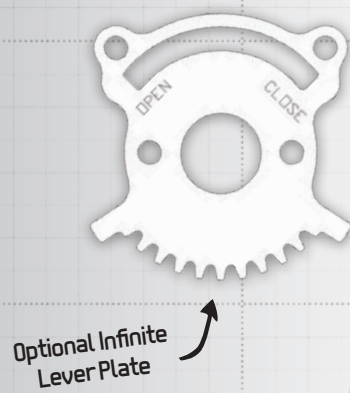

Locking Arm



6 mil PTFE coating over SS disc for extreme corrosion resistance

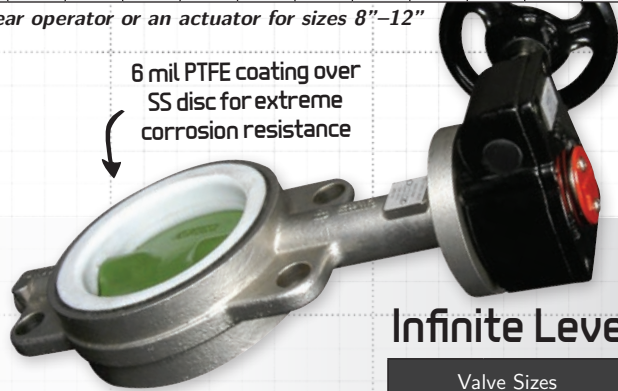

Infinite Lever Details

Valve Sizes		ILP Plate	ILP Arm
in	mm		
2-2.5"	DN50-65	01	01
3"	DN75	01	03
4"	DN100	02	03
5-6"	DN125-150	02	04
8"	DN200*	03	05
10-12"	DN250-300*	03	06

VALVES SHIP WITH STANDARD 10-POSITION THROTTLE PLATE UNLESS ILP PLATE OPTION IS SPECIFIED.

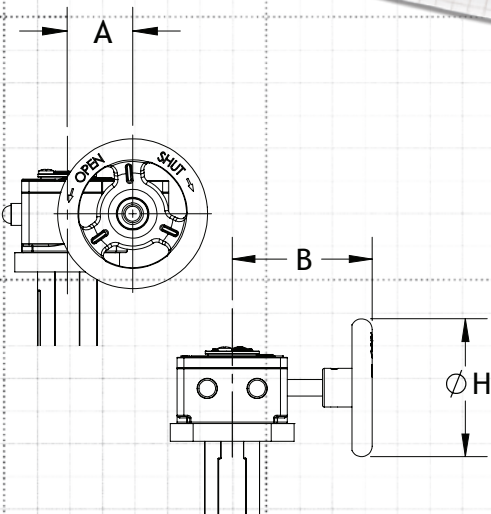

Gear Operator Dimensions—Cast Iron

Valve Sizes		Gear Operator	A		B		ØH		Weight		Output Torque	
in	mm		in	mm	in	mm	in	mm	lbs	kg	in-lbs	Nm
1.5-4	DN50-100	GO-01-ISO	1.7	43	3.2	81	6	152	2.8	1.3	1330	150
5-6	DN125-150	GO-02-ISO	2.5	64	3.6	91	6	152	5.6	2.5	2200	250
8-10	DN200-250	GO-03-ISO	2.4	61	4.7	119	10	254	11.5	5.2	4425	500
12-14	DN300-350	GO-04A-ISO	2.6	66	6.5	165	12	305	22.2	10.1	8850	1000
16-18	DN400-450	GO-05B-ISO	3.5	89	7.9	201	16	406	40.8	18.5	15900	1800
20	DN500	GO-06B-ISO	5.0	127	10.1	257	16	406	78.1	35.4	30090	3400
24	DN600	GO-07-ISO	6.1	155	12.4	315	16	406	101	45.8	39825	4500

DeltaT 050/051 & 650/651 Butterfly Valves

Seat Material Guide



Seat Material (Backing Material)	General Application	Temperature Range at Full Rated Pressure	Not Recommended For
Nitrile Buna-N (NBR) (Phenolic Backing)	Hydrocarbons with less than 40% of aromatics, Natural Gas, Air, H ₂ O, Sea Water, Brine, Alcohols, Glycols	10°F to 180°F	Solvents, Benzene, Xylene
		-12°C to 82°C	
EPDM (Phenolic Backing)	H ₂ O, Saturated Steam*, Air, Brine, Abrasives, Phosphates, Esters, Ketones, Alkali, Food Compounds, Liquids and Solids, Dilute Inorganic Acids, Caustic Soda (*low pressure saturated steam only. Please consult factory for details.)	-4°F to 275°F	Hydrocarbons, Oils, Fats, Dry Air
		-20°C to 135°C	
		-4°F to 302°F	
High Temperature EPDM (Phenolic Backing)		-20°C to 150°C	
Chlorosulfonated Synthetic Rubber (CSM) (Phenolic Backing)	Oxidizing Acids, Chromic Acid, Hydrofluoric Acid, Sulphur Based Acids, Sodium Hypochlorite, Ozone	0°F to 275°F	Steam, Ketones, Hot Air, Nitric Acid
		-18°C to 135°C	
Silicone (Phenolic Backing)	Beverages, Food	-22°F to 400°F	Hydrocarbons, Solvents, Steam
		-30°C to 204°C	
Fluoroelastomer (FKM-VITON) (Aluminum Backing)	Hydrocarbons with high concentration of aromatics, Mineral and Halogenated Acids, Phosphoric Acid, Aliphatic and Aromatic Ethers	0°F to 392°F	Steam, Ketones, Amines, Esters, Alkali
		-18°C to 200°C	
Neoprene (CR) (Phenolic Backing)	Oils, Dilute Mineral Acids, Alkali, Fats	20°F to 200°F	Ketones, Concentrated Acids, Solvents for Paint
		-7°C to 93°C	
Wear Resistant EPDM (Phenolic Backing)	Abrasive Products	14°F to 250°F	Steam, Hydrocarbons, Oils
		-10°C to 120°C	
PTFE Over EPDM (Phenolic Backing) <i>Rated to 150 PSI</i>	Corrosive Products, Solvents	-4°F to 250°F	Abrasive Products, Fluorine Gases, Alkaline Metals
		-20°C to 120°C	

CROSSOVER GUIDE

Body	Ductile Iron						Valve Type
Disc	Ductile Iron-Nickel Plated		Aluminum-Bronze		316 Stainless Steel		
Seat	EPDM	BUNA	EPDM	BUNA	EPDM	BUNA	
	050-262	050-263	050-780	050-783	050-579	050-582	Wafer
	051-262	051-263	051-780	051-783	051-579	051-582	Lug
Bray	30-11010-119	30-11010-713	30-11010-120	30-11010-684	30-11010-124	30-11010-125	Wafer
	31-11010-119	31-11010-713	31-11010-120	31-11010-684	31-11010-124	31-11010-125	Lug
Centerline	A2-021-05	A2-021-01	A2-061-05	A2-061-01	A2-044-05	A2-044-01	Wafer
	B2-021-05	B2-021-01	B2-061-05	B2-061-01	B2-044-05	B2-044-01	Lug
Demco	NE-C111535_	NE-C111531_	NE-C111435_	NE-C111431_	NE-C112235_	NE-C112231_	Wafer
	NE-C511535_	NE-C511531_	NE-C511435_	NE-C511431_	NE-C512235_	NE-C512231_	Lug
Grinnell	WD-820_-3	WD-810_-3	WD-828_-3	WD-818_-3	WD-827_-4	WD-817_-4	Wafer
	LD-820_-3	LD-810_-3	LD-828_-3	LD-818_-3	LD-827_-4	LD-817_-4	Lug
Jenkins	_223E_J	_223B_J	_222E_J	_222B_J	_221E_J	_221B_J	Wafer
	_233E_J	_233B_J	_232E_J	_232B_J	_231E_J	_231B_J	Lug
Keystone	AR1-323	AR1-285	AR1-061	AR1-064	AR1-805	AR1-723	Wafer
	AR2-323	AR2-285	AR2-061	AR2-064	AR2-805	AR2-723	Lug
Kitz	5112E	5112B	5122E	5122B	5141E	5141B	Wafer
	6112E	6112B	6122E	6122B	6141E	6141B	Lug
Milwaukee	MW-232-E	MW-232-B	MW-233-E	MW-233-B	MW-234-E	MW-234-B	Wafer
	ML-232-E	ML-232-B	ML-233-E	ML-233-B	ML-234-E	ML-234-B	Lug
Mueller Steam	SERIES 51	SERIES 51	87-INB6	87-INB3	87-INH6	87-INH3	Wafer
	SERIES 52	SERIES 52	88-INB6	88-INB3	88-INH6	88-INH3	Lug
NIBCO	WD-2010	WD-2110	WD-2000	WD-2100	WD-3022	WD-3122	Wafer
	LD-2010	LD-2110	LD-2000	LD-2100	LD-3022	LD-3122	Lug

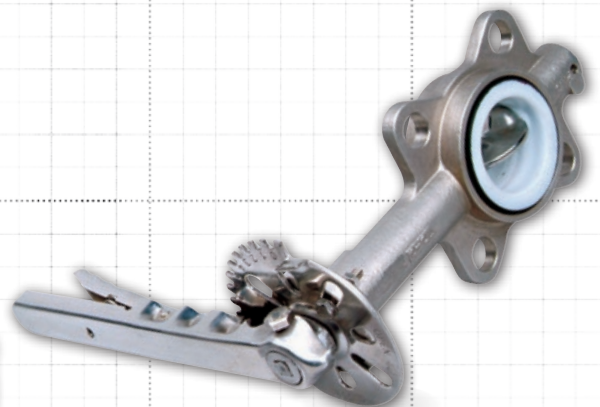
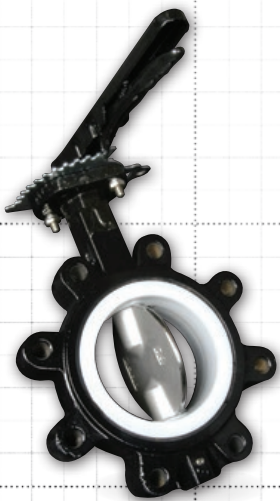



THE BRAND
BY WHICH ALL
OTHERS ARE MEASURED
DELTA T PRODUCTS



CAUTION

The technical data contained herein regarding operating torque, flow capacity, pressure and temperature range, etc. have been compiled from factory testing, field service, engineering calculations, and generally available technical specifications. This information is intended to serve as general parameters for specifying and sizing the valves in this brochure for standard service. For non-standard applications, or where there is any confusion or uncertainty about the technical data provided in this document, please contact your local distributor for advice pertaining to the specific application and/or perform application-specific testing to assess/confirm the suitability of these valves.

The data and specifications in this brochure are correct to the best of our knowledge; however, we take no liability for inaccuracy thereof or for any damage or injury as a result of such errors or of using these valves outside of the recommended specifications, and all information herein may be subject to change without notification as deemed necessary by the factory.

For Distributors and Availability Contact:

